

# **Kurt J. Lesker**<sup>®</sup> Company

## **Operating and Maintenance Handbook**

All Metal Valves, CR & CRD Right Angle Valve Series  
CSD Straight Through Series, LVM & MD Leak Valve Series



# Contents

1.0	Introduction	3
1.1	The CR, CRD and CSD Series of All Metal Valves	3
1.2	The LVM and MD Series of All Metal Leak Valves	3
1.3	Sealing Principle	4
1.4	New Valves	4
1.5	Maintaining a Leak-Tight Seal	4
1.6	Lubrication	5
1.7	Bakeout	5
1.8	Reconditioning and Servicing	5
2.0	Specifications for the CR, CRD and CSD Series	6
2.1	Changing the Copper Sealing Pad	6
2.1.1	Valves with Welded Bonnet Seals	7
2.1.2	Valves with Demountable Bonnet Seals	7
2.2	CSD Pad Replacement Procedure	7
3.0	The CRT7 Series of All Metal Valves	9
3.1	Specifications of the CRT Series Valves	9
3.2	CRT7 Pad Replacement Procedure	9
3.3	CRT7 Knife-edge Replacement	11
4.0	The MD Series of All Metal Leak Valves	11
4.1	Specification of the MD Series of All Metal Leak Valves	12
4.2	MD5 Leak Valve - Coarse Version	12
4.2.1	Operation	12
4.2.2	Bakeout	13
4.2.3	Dismantling the Valve to Replace the Diaphragm	14
4.2.4	Testing the Performance of the Valve	14
5.0	LVM Series Leak Valves	15
5.1	Operation	15
5.2	Bakeout	16
5.3	Maintaining a Leak-tight Seal	16
5.4	Calibrating the Valve	17
5.5	LVM Series Pad Replacement Procedure	18
6.0	Spares and Accessories for All Metal Valves	18
6.1	CR, CRD and CSD Valves	18
6.2	MD Leak Valves	19
6.3	LVM Leak Valves	19

## **1.0 Introduction**

All metal vacuum valves are used in applications where any organic material cannot be tolerated, and, more typically, where bakeout temperatures in excess of 200°C are required. The KJLC® wide range of all metal valves can be broadly divided into two categories:

- 1) The CR and CRD range of all metal right angle valves. These are heavy duty valves with good conductance. The CSD in-line valve also falls into this category
- 2) The LVM and MD range of all metal leak valves

### **1.1 The CR, CRD and CSD Series of All Metal Valves**

CR, CRD and CSD ranges of all-metal valves use a sealing technique based on the deformation of a copper pad against a knife edge. This method of sealing has been shown to provide a consistent UHV seal for many thousands of operating cycles. The CR series are right-angle valves with welded bonnet seals. The CRD series are right-angled valves with demountable bonnet seals. The CR (D) series are available in three sizes - CR (D)20,40 and 60 (corresponding approximately to the valve port diameters in millimeters). The CSD32 is a line-of-sight valve with a clear bore of 32mm. Both flanged and tubulated (unflanged) versions of all valves are available.

### **1.2 The LVM and MD Series of All Metal Leak Valves**

These all metal leak valves can be used to very accurately control the flow of gas into a vacuum system from an external source (e.g., the gas feed to an ion gun). Leak valves use the same basic principle of sealing as do other all metal valves; a softer metal pad is forced against a harder metal seat. Two major differences between leak valves and other all metal valves are.

- 1) The knife edge has a truncated profile which allows the passage of gas to be carefully controlled as the sealing force is released.
- 2) The relative movement between knife edge and sealing pad is accurately controlled.

### **1.3 Sealing Principle**

The seal in an all-metal valve is created by elastically deforming an OFHC copper pad against a knife edge. When a new pad is fitted, the initial closure of the valve is carried out at a higher than normal torque level. This is called seal formation and causes permanent deformation of the relatively soft sealing pad against the harder knife edge. Subsequent operations at the lower torque level will elastically compress the pad but not cause further permanent deformation.

Exceeding the stated operating torque can actually make the seal less reliable. If done accidentally, the seal should be reformed at the forming torque and then the normal operating torque can continue to be used.

### **1.4 New Valves**

New valves have had their seals factory formed, and are shut off to the minimum torque level required to seal the valve. During the first bakeout some stress relaxation of the pad and drive components can occur. It is therefore recommended that the shut-off mark be reset at the lowest level of operating torque necessary to seal the valve after the first bakeout is complete. Occasional torque checks are advisable, particularly if bakeout temperature or duration is increased.

Stress relaxation may also occur to a lesser extent when new copper pads are fitted. With demountable valves the bonnet bolts will also relax after the first bakeout and should be retightened with the valve opened.

### **1.5 Maintaining a Leak-Tight Seal**

Do not exceed the stated operating torque under normal circumstances.

Minimize the possibilities of abrasive particles entering the valve. Particles embedded in the relatively soft copper pad are by far the most common cause of leaks in all-metal valves. New valves should not be operated unless under vacuum.

If the valve has been subjected to long periods of bakeout, the compressive force may have relaxed. Relubricate the valve drive screw. Use a torque wrench to achieve the correct operating torque. Reset the adjustable index collar (where fitted).

If the sealing pad has been damaged by contamination it may be sufficient to simply increase the operating torque within the available range. If this is not successful, reform

the seal at a higher forming torque, and then operate the valve at a proportionately higher operating torque.

For CR, CRD and CSD valves do not exceed the values given in the section 2.1 by more than 20%. If operating at higher torque fails to achieve a satisfactory seal, the copper pad must be changed. If the knife edge is damaged it will be necessary to return the valve to the factory for reconditioning.

## **1.6 Lubrication**

Occasional lubrication of the drive screw, using lubricant (part code VZTL), is advisable when the valve is subjected to long term or high temperature bakeouts. The thread should be carefully cleaned with a wire brush before applying fresh lubricant. Do not over apply as this will cause a build up inside the mechanism which can cause the thread to seize up.

## **1.7 Bakeout**

The valves may be baked to 450°C (350°C Max for only the Series CR(D)20 valves) in the open position and 300°C in the closed position. If the valve is closed during bakeout, both sides of the valve should be under vacuum. Under no circumstances should the standard valves be baked with any of the internal structure exposed to atmosphere. This will result in oxide formation occurring on the copper sealing pad which impairs the performance of the valve. Special pads are available if exposure to oxygen is unavoidable.

## **1.8 Reconditioning and Servicing**

All bakeable valves may be reconditioned at the factory. They should be returned delivery paid to the address shown on the Declaration of Product Safety form which can be found at [www.lesker.com](http://www.lesker.com). Information regarding the apparent fault should be supplied with the returned product wherever possible.

### *Safety Note:*

*When returning valves to our factory, it is very important that you advise us of any hazardous compounds to which the valve may have been exposed. Otherwise, repair and or servicing of equipment will not be undertaken unless the item is accompanied by a completed product safety form.*

## 2.0 Specifications for the CR, CRD and CSD Series

Valve	Flanges	Conductance	Forming torque Nm (ftlb)	Operating Torque Nm (ftlb)
CR7	NW16CF	0.05	See Text*	0.7 - 1.1 (0.5 - 0.9)
CR(D)20	NW16CF	5	4.7 (3.5)	2.4 - 3.7 (1.7 - 2.7)
CR(D)40	NW35CF	34	15.4 (11.4)	7.7 - 12.1 (5.7 - 8.9)
CR(D)60	NW63CF	100	38 (28.1)	19 - 29.9 (14 - 22.1)
CSD32	NW35CF	20	46.3 (34.1)	23.2 - 36.3 (17.1 - 26.8)

\* CR7 valves are pre-formed. They are of welded construction and there are no user serviceable parts. The valves must be returned to the factory for pad or knife edge replacement.

## 2.1 Changing the Copper Sealing Pad

The copper pad is simply screwed into the movement assembly. A machined slot is provided in the pad for the removal tool (use a large screwdriver on size 20 valves). Some valves have a disc spring or Belleville washer behind the copper pad; take care that this does not get displaced when the pad is removed.

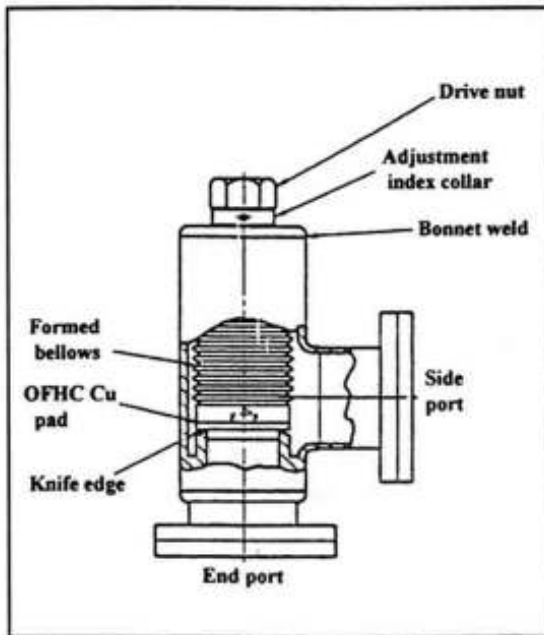

Figure 1. Welded bonnet valve.

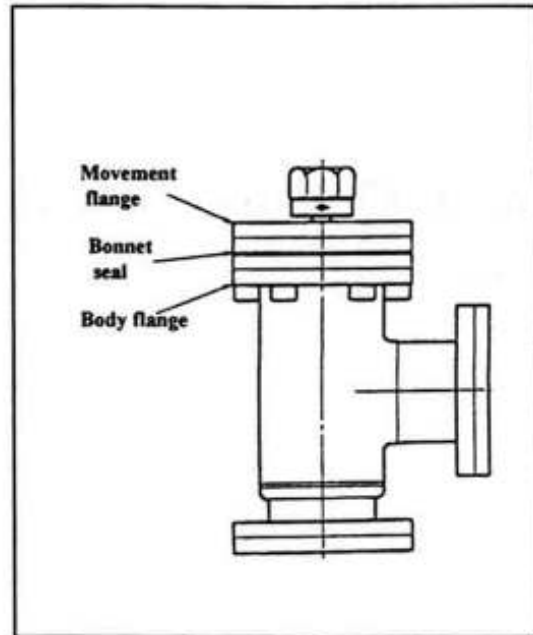

Figure 2. Demountable bonnet valve.

*Note: Take care not to damage the area of the pad which will form the sealing face when replacing the new pad in the valve.*

### **2.1.1 Valves with Welded Bonnet Seals**

To access the pad on valves with welded bonnet seals, remove the valve from the system. The pad can then be unscrewed through the end port and withdrawn, using tweezers or the removal tool to hold the threaded stub, through the side port.

### **2.1.2 Valves with Demountable Bonnet Seals**

Valves with demountable movements need not be removed from the system. With the valve open, unscrew the bonnet bolts which clamp the bonnet seal. The conflat knife edge of this seal should be protected at all times, particularly against abrasive oxide particles which may have formed on the copper bonnet gasket of valves subject to high temperature bakeout (silver plated gaskets are available to avoid this problem). Replace the pad as described above. Clean and lubricate the bonnet bolts before refitting.

*Note: If necessary, the complete movement assemblies can be replaced for the demountable valves.*

## **2.2 CSD Pad Replacement Procedure**

The sealing pads on CSD valves can only be replaced by demounting the valve body and exactly the same procedure as for CRD valves should be followed (see section 2.2). The sealing pad is secured by set screws in the periphery of the backing plate. Refer to figure 3.

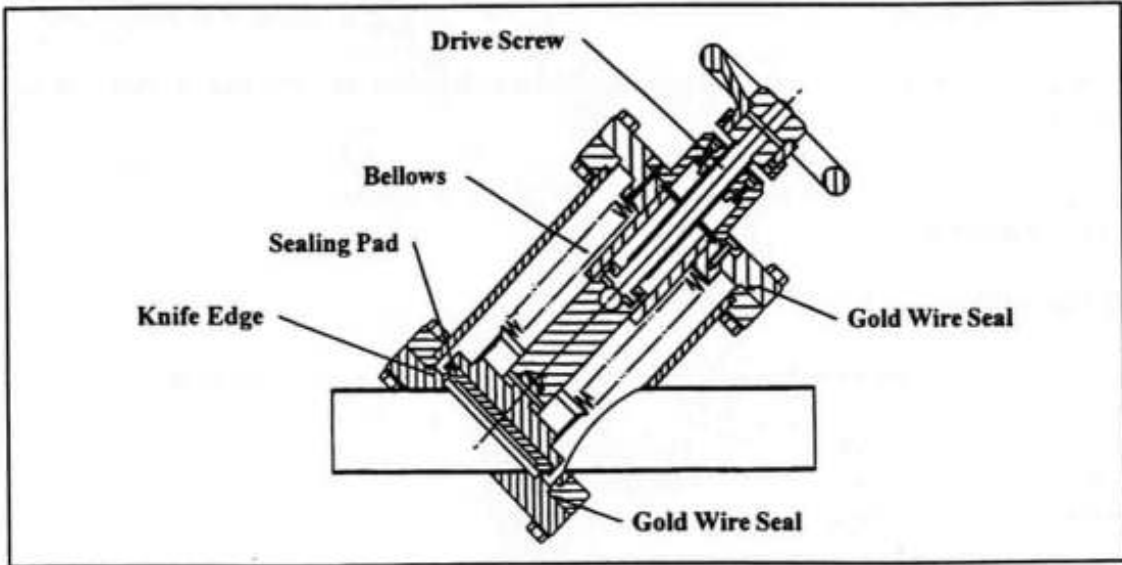

Figure 3. The CSD32 in-line all metal valve.

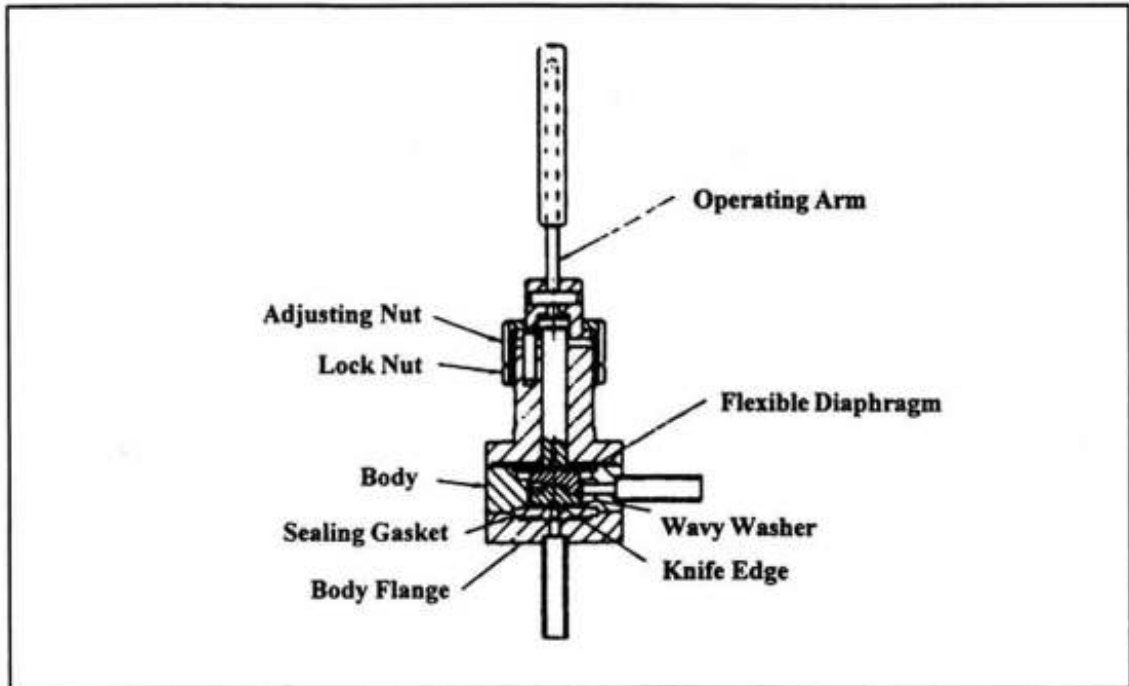

Figure 4. The CRT7 all metal valve.



### 3.0 The CRT7 Series of All Metal Valves

The principle of operation of the CRT7 valve is illustrated by figure 4. Since the diameter of the seal is small, the required sealing load is also small and a drive screw operating mechanism is not necessary. Instead, the sealing load is provided as the operating arm is rotated causing its eccentric profile to act on the plunger.

The CRT7 is an all-metal valve of demountable construction. Its low dead-volume makes it suitable for gas handling applications.

Please note that the plastic sleeve on the operating arm is not bakeable and must be removed prior to bakeout.

### 3.1 Specifications of the CRT Series Valves

Valve	Configuraflon	Terminations	Open Conductance $l s^{-1}$
CRT7U	90°	Plain tube 7mm	0.05
CRT97R	90°	34mm Conflat	0.05
CRT7TU	Tee	Plain tube 7mm	0.05
CRT97TU	Tee	34mm Conflat	0.05

### 3.2 CRT7 Pad Replacement Procedure

The sealing pad in CRT7 valves is a special copper gasket which also forms the body-flange seal (see figure 4). Replacement sealing pads are available from Vacuum Generators. To replace the sealing pad follow the procedure given below:

1. Open the valve. Using the 'C' wrench provided, slacken the lock-nut and the adjusting nut. Place the valve upside down in a soft-jaws vice.
2. Remove the six cap-head screws securing the body flange to the body.
3. Remove the body flange. If the seal does not separate, slowly operate the lever to ease the components apart.
4. Remove the copper gasket from the knife-edge.
5. Check that the knife-edge recess and plunger knife-edge are free from damage and clean them with a lint-free tissue moistened with alcohol. DO NOT draw the tissue radially across the knife-edge.

6. Position the new copper gasket in the knife-edge recess.
7. Reassemble the valve in reverse order, tightening the body flange screws evenly.
8. Remove the valve from the vice.

When the new seal is being formed it is desirable to have a helium mass spectrometer leak detector available. A simplified procedure is given below (point 13 onwards) for CRT7 owners who do not possess this facility.

9. Put the operating lever in the closed position. Using the 'C' wrench tighten the adjusting nut in small increments (approx 1/4 turn) until the valve seals.
10. Tighten the lock-nut, taking care not to move the adjusting nut.
11. Operate the valve a few times.
12. Check the valve again on the leak detector. If it leaks, tighten the adjusting nut a little further until it seals.

If a helium mass spectrometer leak detector is not available adopt the following procedure:

13. Put the operating lever in the closed position.
14. Tighten the adjusting nut by hand until resistance is felt (indicating the knife-edge coming into contact with the sealing pad)
15. Using the 'C' wrench advance the adjusting nut through 180°.
16. Tighten the lock-nut taking care not to move the adjusting nut.
17. Operate the lever a few times.
18. The valve should be leak tight but any check possible is strongly advisable.

Please note that whenever the valve is demounted (the body flange removed from the body) it is imperative that the sealing pad is replaced.

### 3.3 CRT7 Knife-edge Replacement

Before replacing the knife-edge, the body should be demounted from the body flange as described in steps 1 to 4 of section 3.2.

1. Lift out the wavy washer situated between the knife-edge and the sealing gasket.
2. Remove the valve from the vice and turn it up the correct way. The knife-edge should drop out.
3. Put the valve back in the vice as before and fit the new knife-edge component.
4. Check that the knife-edge recess and plunger knife-edge are free from damage and clean them with a lint-free tissue moistened with alcohol. DO NOT draw the tissue radially across the knife-edge.
5. Reassemble the valve following steps 7 to 18 of section 3.2.

Please note that whenever the valve is demounted (the body flange removed from the body) it is imperative that the sealing pad is replaced. It is a wise precaution to replace the wavy washer (mentioned in step 1 above) at the same time.

### 4.0 The MD Series of All Metal Leak Valves

The operating principle of a leak valve is similar to normal all-metal valves in that a soft metal sealing pad is compressed against a harder metal knife-edge. However there are major differences, namely:

- 1) The knife-edge has a truncated profile.
- 2) The relative movement between the knife-edge and the sealing pad can be carefully controlled enabling the passage of molecules to be regulated as the compressive sealing force is relaxed. The procedure for setting up and calibrating the seal on a leak valve is not easy and several attempts with new sealing members are sometimes required.

For this reason it is recommended that if maintenance becomes necessary the valve is returned to the factory. However, instructions are given below for users who wish to attempt maintenance themselves. Access to a helium mass spectrometer leak detector is assumed.

## 4.1 Specification of the MD Series of All Metal Leak Valves

Valve	Configuration	Terminations	Open Conductance ls <sup>-1</sup>
<b>Coarse Version - MD5</b>			
MD9538	90°	70mm-/34mm OD	0.1
MD95	90°	34mm OD	0.1

## 4.2 MD5 Leak Valve - Coarse Version

The MD5 is illustrated in figure 5. It is specially designed for handling hot and/or corrosive gases, and for this reason it is constructed from corrosion-resistant materials. The body is made from stabilised stainless steel and instead of the normal sealing member materials; the valve has a stellite-faced knife edge and a nickel diaphragm. The latter not only forms the sealing pad but is also an integral part of the vacuum envelope which minimises the dead volume of the valve.

The leak rate is continuously controllable from  $10^2$  to  $10^{-7}$  mbar ls<sup>-1</sup>. Below  $10^{-7}$  mbar ls<sup>-1</sup> the leak cannot be easily controlled, but when the valve is fully closed the leak rate is below  $10^{-11}$  mbar ls<sup>-1</sup>.

The operating mechanism consists of a drive screw, a set of disc springs and a pressure pad through which the load is transmitted to the nickel diaphragm. On the reverse side of the diaphragm, a second set of disc springs provides a restoring force. If for any reason the valve is dismantled, it is important that the two sets of springs are replaced correctly. The stronger springs (0.8mm thick) should be positioned above the diaphragm, and the weaker springs (0.7mm thick) below the diaphragm.

The drive screw has a bonded dry lubricant on all faces. The film of lubricant should last for a long time, but with prolonged use at high temperature there may be some deterioration. The drive screw can easily be unscrewed and either replaced or have additional lubricant added (see section 1.7).

### 4.2.1 Operation

The MD5 is supplied in the fully-closed position. To open the valve, insert the drive key and gradually rotate in a counterclockwise direction until the desired leak rate is achieved. The admission of large volumes of air (or other gas) at high leak rates, especially if the valve is at room temperature, may cause water vapor to be condensed on the underside of the diaphragm. The presence of water vapor or a similar absorbed film will prevent the

valve from functioning at small leak rates and must be removed to restore correct operation.

The recommended operating temperature range is from  $-100^{\circ}\text{C}$  to  $+300^{\circ}\text{C}$ . In the event of a leak at the valve body seal, i.e., between the diaphragm and the valve body, further tighten the six socket head screws a little at a time and as uniformly as possible

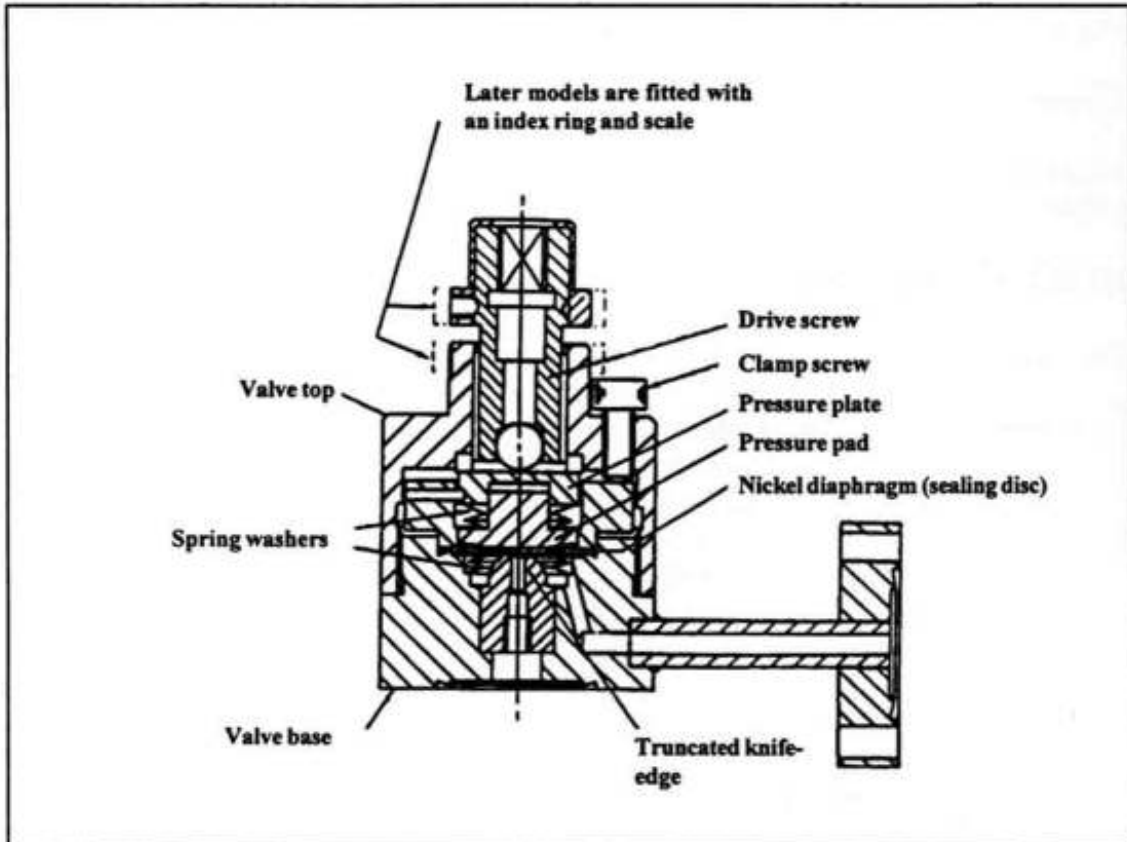

Figure 5. The MD5 coarse leak valve.

until the leak seats. If the leak persists it is likely that the diaphragm has become damaged and needs replacing.

#### 4.2.2 Bakeout

The maximum recommended bakeout temperature for the MD5 is  $450^{\circ}\text{C}$ , and it may be baked either the open or closed position. It is recommended that the drive key is removed during bakeout.

### 4.2.3 Dismantling the Valve to Replace the Diaphragm

1. Fully open the valve. Refer to figure 5.
2. Release all six socket head screws preferably with the base of the valve in a horizontal plane.
3. Unscrew the valve top (turn counterclockwise) from the base and remove the annular pressure plate, the top spring set assembly and finally the diaphragm and lower spring set.
4. Clean the valve seat with a lint free tissue moistened with alcohol and carefully examine the seal to ensure that it is undamaged and free from all foreign matter.
5. Clean and examine a replacement nickel diaphragm and also the lower spring set and reassemble in the reverse order.
6. Tighten the six socket head screws uniformly and sufficiently to form a vacuum tight joint. This will normally be achieved with a penetration of the knife edge into the diaphragm of approximately 0.1 mm. Too large a penetration can have the effect of reducing the open conductance of the valve.
7. Using a torque wrench close the valve and apply a torque of  $25 \text{ kgcm}^{-1}$  which should be sufficient to form a good surface on the diaphragm and shut off the valve.

### 4.2.4 Testing the Performance of the Valve

Where possible it is desirable to check the performance of the valve on a helium leak detector, since it is necessary to reset the index ring at the shut-off point of the valve. This is normally done by partly opening the valve, (after application of the seat forming torque) and closing it until the shut off point is determined. The valve should then be gradually opened, which should cause the leak rate to progressively increase. Once outside of the range of the helium leak detector, it is advisable to use dry nitrogen as the gas feed if it is intended to check the operation of the valve over the full leak range. This will avoid condensation of water vapor on the underside of the diaphragm.

Generally, the smaller the torque that is used to form the seal the smaller will be the sensitivity at small leak rates, i.e.  $10^{-7} \text{ mbar ls}^{-1}$  and below.

Increasing the seal forming torque will increase the sensitivity of the valve and also tend to reduce the open conductance.

## 5.0 LVM Series Leak Valves

The LVM range of leak valves all share the same operating mechanism and method of calibration and operation, because of this all illustrations given will be of the LVM940. The LVM940 leak valve is illustrated by figure 6. The movement between the knife-edge and the sealing face is controlled by means of the control knob which acts on a long lever, thereby giving very high sensitivity of movement. The movement in the vacuum envelope is taken up by a flexible stainless steel diaphragm, but unlike the MDS, the knife-edge is carried on the moving copper alloy pad. The LVM valves are all fully demountable enabling the copper alloy sealing pad and stainless steel sealing face to be replaced and/or serviced.

The LVM valves are continuously controllable between  $10^{-3}$  and  $10^{-11}$  mbar ls<sup>-1</sup>. The fully closed leak rate is  $<10^{-11}$  mbar ls<sup>-1</sup>.

Because of the lever action used it is possible to 'tune' the valve to suit the gas and the operating range required. This is referred to as 'mapping' and is dealt with later in this section.

### 5.1 Operation

The LVM valves are supplied leak checked to helium and in the fully closed position with the zero on the control knob aligned with the zero mark on the lever. The valve is opened by arming the control knob in a counterclockwise direction. The initial leak will be very slow as the valve must be 'conditioned' before consistent operation can be guaranteed.

The admission of large volumes of air or wet cold gas may cause undesirable fluids to be condensed on the internal faces of the valve. It is therefore recommended that only pure filtered gas is admitted at the same temperature as the valve. This will avoid contamination and the possibility of gas condensation.

The recommended operating temperature range for these valves is from  $-100^{\circ}\text{C}$  to  $+300^{\circ}\text{C}$ . Prolonged operation at elevated temperatures will affect the long term performance of the valve and may necessitate a re-calibration.

***Warning - High temperature operation should never be attempted with a pressure greater than about  $10^{-3}$  mbar on either side of the valve.***

## 5.2 Bakeout

The maximum recommended bakeout temperature for the LVM is 450°C. This should only be done with the valve open and under vacuum, to prevent any oxidation of the internal surfaces, as this would adversely affect the later performance of the valve. It is however possible to bake these valves to 250°C with the valve closed. After prolonged high temperature bakes it may be necessary to re-lubricate the drive screw with a light coating of Felpro®.

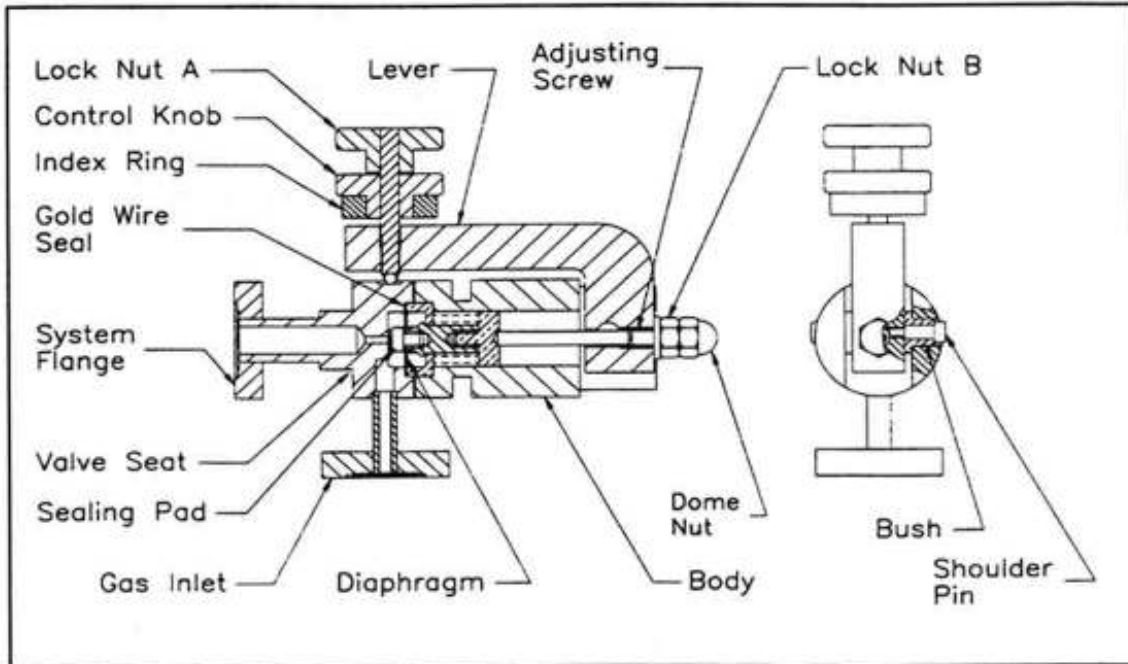

Figure 6

## 5.3 Maintaining a Leak-tight Seal

There are two means of adjusting the compressive forces between the knife-edge and the sealing face: these are the control knob and the adjusting screw (see figure 6).

If after a period of time it is found that the valve is no longer leak tight, it is possible to re-set the closed position by turning the adjusting screw by 2 or 3 degrees. To do this remove the dome nut and loosen the lock-nut B, carefully rotate the adjusting screw clock-wise, then re-tighten the lock-nut B. This process may be repeated several times until it is found that a leak-tight seal cannot be maintained. At this point the pad must be replaced (ref. section 5.5).



## 5.4 Calibrating the Valve

The adjusting screw is used to set up the valve for correct operation by changing the start angle of the operating lever.

Each new valve is factory set to be compatible with helium. This is to ensure that the valve is leak tight and will perform correctly with the most difficult of gases to control. To re-set the valve to suit other gases the following procedure should be followed:

1. Purge the valve with the gas that is to be controlled.
2. Operate the valve through five full operations (fully closed to fully open). This will ensure that the knife-edge is conditioned.
3. From the closed position gradually open the valve until a leak of the controlled gas can be detected. Close the valve by 10 divisions.
4. Re-set the zero position of the control knob by releasing the lock-nut A, and turning the control knob until it contacts with the washer, re-tighten the lock-nut A.

*Note: Care must be taken not to turn the control screw as this could prevent the valve from sealing.*

5. Operate the valve through five full operations (fully open to fully closed).
6. From the closed position gradually open the valve until a leak of the controlled gas can be detected and close again. This should ensure that the valve is both controlling the desired gas and is capable of shutting it off.

If the desired gas to be controlled is changed or the valve requires re-calibrating then repeat steps 1 to 6.

Each valve has its own 'map', that is the shape of the curve that would be produced if the leak rate was plotted against the number of graduations moved on the control knob. This 'map' can be adjusted by changing the start angle of the operating lever to the valve body. To achieve this fine tuning of the valve it is necessary to experiment by adjusting both the control knob and the setting screw. When the desired characteristics are reached it will be necessary to re-check that the valve shuts off.

## 5.5 LVM Series Pad Replacement Procedure

1. Open the valve fully by rotating the control knob counterclockwise.
2. Remove the six cap head screws that secure the valve seal to the body.
3. Separate the two halves of the valve and lift out the seal assembly.
4. Remove the gold wire seal, taking great care not to damage the sealing face.
5. Inspect the knife edge. If it shows any signs of damage it must be replaced.
6. Remove the copper pad with the tool provided and replace with a new item from the service kit.
7. Clean both the gold wire sealing surfaces and the new pad with a lint-free tissue moistened with alcohol. DO NOT draw the tissue radially across the knife-edge.
8. Carefully place the new gold wire seal into the valve seat, lower the seal assembly into the valve seal and slide the valve body down over the seal assembly.
9. Fasten the two halves of the valve together with the cap-head screws and tighten until the body and the valve seat are solidly and evenly clamped together.

This completes the replacement of the pad. The valve must now be re-calibrated as described in section 5.4

## 6.0 Spares and Accessories for All Metal Valves

A complete range of spares and accessories are available for the Vacuum Generators range of all-metal valves. These include toolkits with drive socket, lubricant, hexagon keys and pad removal tool (as appropriate).

### 6.1 CR, CRD and CSD Valves

<b>Order Code</b>	<b>Description</b>
VZCR20C	OFHC Copper Pad for CR20 and CRD20 Valves
VZCR40C	OFHC Copper Pad for CR40 and CRD40 Valves
VZCR60C	OFHC Copper Pad for CR60, CRD60 and CSD32 Valves
VZCR60C	OFHC Copper Pad for CSD32 Valves with Serial Number >S2645

VZCU19	Copper Gaskets for CRD20 Bonnet Seal
VZCU38	Copper Gaskets for CRD40 Bonnet Seal
VZCU64	Copper Gaskets for CRD60 and CSD32 Bonnet Seal
VZCRD20MA	Movement Assembly for CRD20
VZCRD40MA	Movement Assembly for CRD40
VZCRD60MA	Movement Assembly for CRD60
VZCR20TK	Toolkit for CR20 and CRD20 Valves
VZCR40TK	Toolkit for CR40 and CRD40 Valves
VZCR60TK	Toolkit for CR60 and CRD60 Valves
VZCSD32TK	Toolkit for CSD32 Valve
VZCRHW	Handwheel for CR/CRD40 and CR/CRD60 Valves

## 6.2 MD Leak Valves

Order Code	Description
VZMD5SK	Repair Kit for MD95 Valves
VZMD6SK	Repair Kit for MD6 Valves up to Serial Number MD2503
VZMD6ASK	Repair Kit for MD6 Valves for Serial Numbers MD2504-MD2605
VZMD6MSK	Repair Kit for MD6 Valves of Serial Number MD2606 and above
VZMD7SK	Repair Kit for MD7 Valves of Serial Number MD2544
VZMD7MSK	Repair Kit for MD7 Valves of Serial Number MD2545 and above

## 6.3 LVM Leak Valves

Order Code	Description
VZLVMSK	Repair kit for all LVM Series Valves
VZLVMPK	Replacement pad kit for all LVM Series Valves